

# Low Noise Amplifier

## PRODUCT DATASHEET

## RFLNAM12\_EV1

### Features:

- RF Frequency: 8 - 12 GHz
- Small signal gain: 22.5 dB
- Noise Figure: 1.78 dB
- Output P1dB: 17.8 dBm
- Saturated Output Power: 20.8 dBm
- DC drain bias voltage: 4 V
- DC supply current: 90 mA.
- DC Gate Bias Voltage: -0.5 V
- 0.1um GaAs pHEMT Technology.
- Die Size: 1.15 mm \* 1.78 mm.

### Applications:

- Radar Systems
- SATCOM
- Electrical Warfare

### Deliverables:

- Sample Ready Die
- Test Results

### Functional Block Diagram:

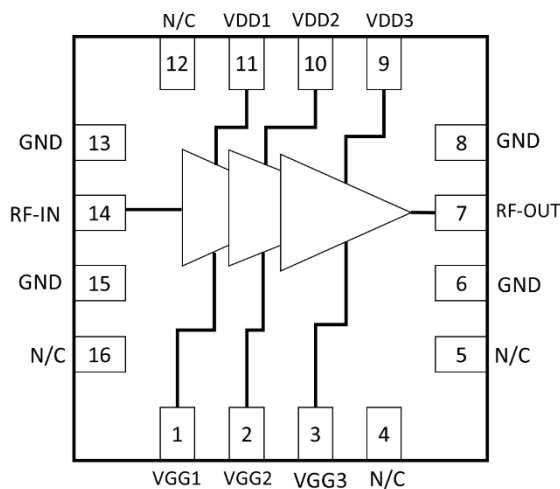

### Pin Configuration:

Pin No.	Pin Name	Description
6,8,13,15	GND	Ground
11	VDD1	Drain Bias Voltage 1
10	VDD2	Drain Bias Voltage 2
9	VDD3	Drain Bias Voltage 3
1	VGG1	Gate Bias Voltage 1
2	VGG2	Gate Bias Voltage 2
3	VGG3	Gate Bias Voltage 3
14	RF-IN	RF Input
7	RF-OUT	RF Output
4,5,12,16	N/C	Not Connected

### Description:

RFLNAM12 is a three-stage Low Noise Amplifier operating from 8-12 GHz, intended for front-end signal amplification in RF receiver systems. The amplifier provides 21 dB of small-signal gain, with input and output matched to 50 ohms using on-chip DC blocking capacitors.

The device is specifically designed for use in Fixed Wireless Broadband, Microwave Links, WiFi, IoT, SATCOM, and Radar Systems Applications.

The Technology used to design the LNA is a 0.1 μm GaAs pHEMT Process.

Signify RF confidential property not to be copied or disclosed without prior authorization.

### Electrical Specification:

Freq= 8 - 12 GHz, VDD1=VDD2= VDD3=4V, VGG1=VGG2=VGG3= -0.5V, ID= 90 mA, Zo=50 Ω

Parameters	Test Condition	Units	Typ
Gain	8 GHz	dB	21.5
	10 GHz		22.5
	12 GHz		24
Output P1 dB	8 GHz	dBm	
	10 GHz		17.8
	12 GHz		
OIP3 Pin = -23 dBm Δf = 100 kHz	8 GHz	dBm	
	10 GHz		27.2
	12 GHz		
Noise Figure	8 GHz	dB	
	10 GHz		1.78
	12 GHz		
Input Return Loss	8 GHz	dB	
	10 GHz		13
	12 GHz		
Output Return Loss	8 GHz	dB	
	10 GHz		6
	12 GHz		
<b>Operating Bias Conditions</b>			
Drain Current (Id)	-	mA	90
Drain Voltage (VDD)	-	V	4
Gate Voltage (VGG)	-	V	-0.5

# Low Noise Amplifier

## PRODUCT DATASHEET

## RFLNAM12\_EV1

### EVB Test Results:

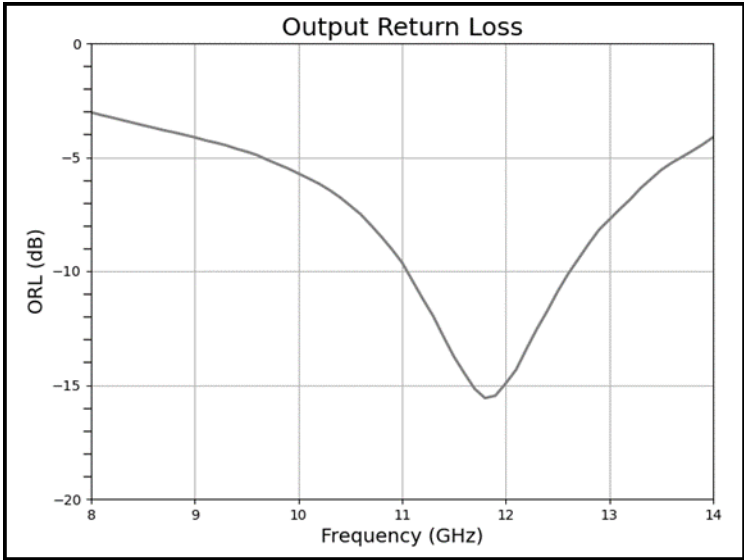
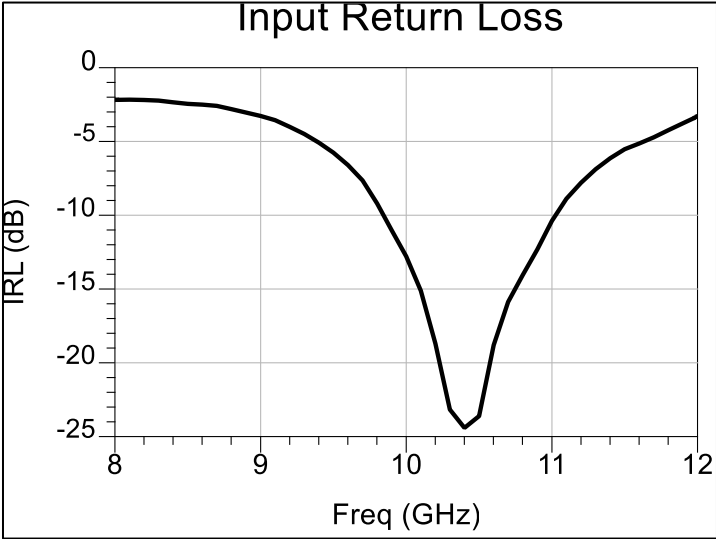
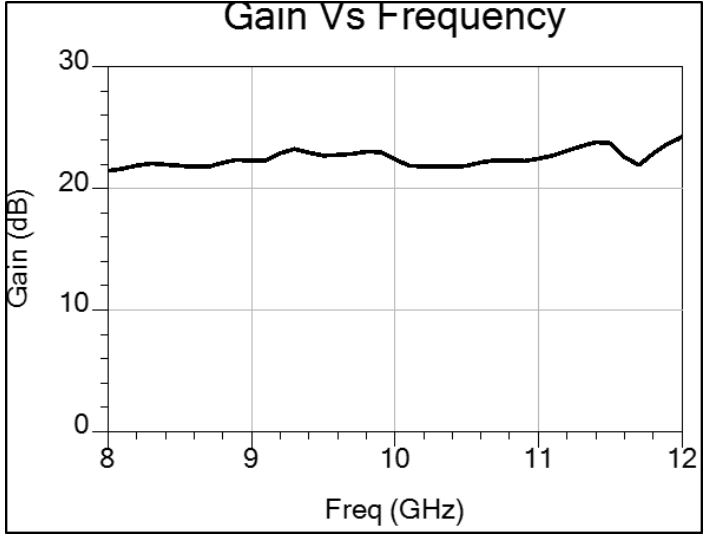

# Low Noise Amplifier

## PRODUCT DATASHEET

## RFLNAM12\_EV1

### Typical Performance Curves:

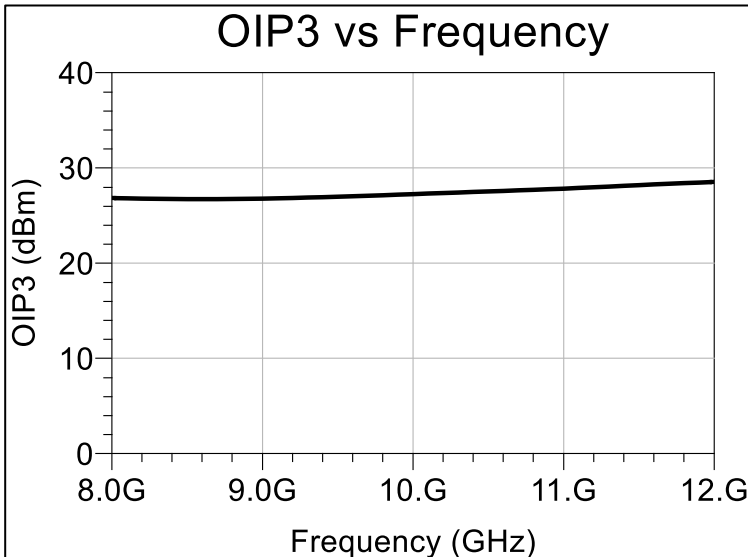
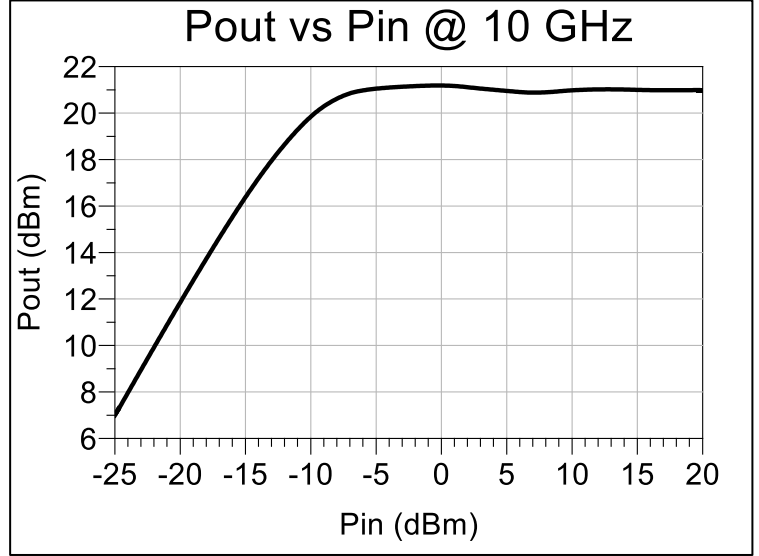
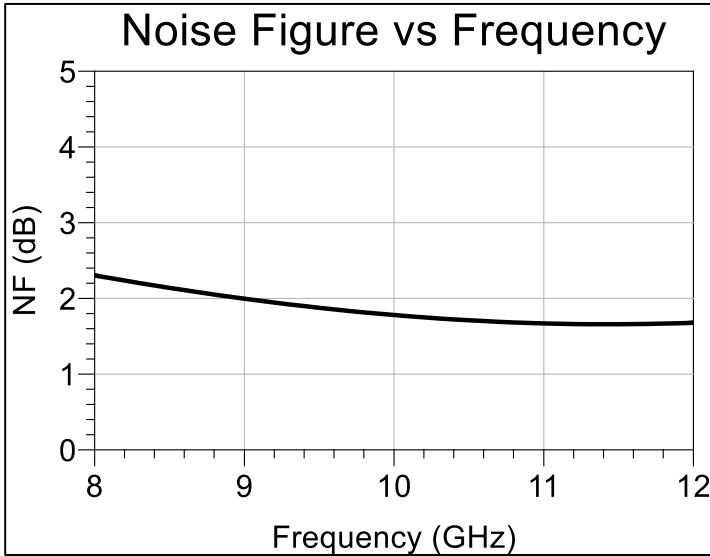

# Low Noise Amplifier

## PRODUCT DATASHEET

## RFLNAM12\_EV1

### Application Diagram:

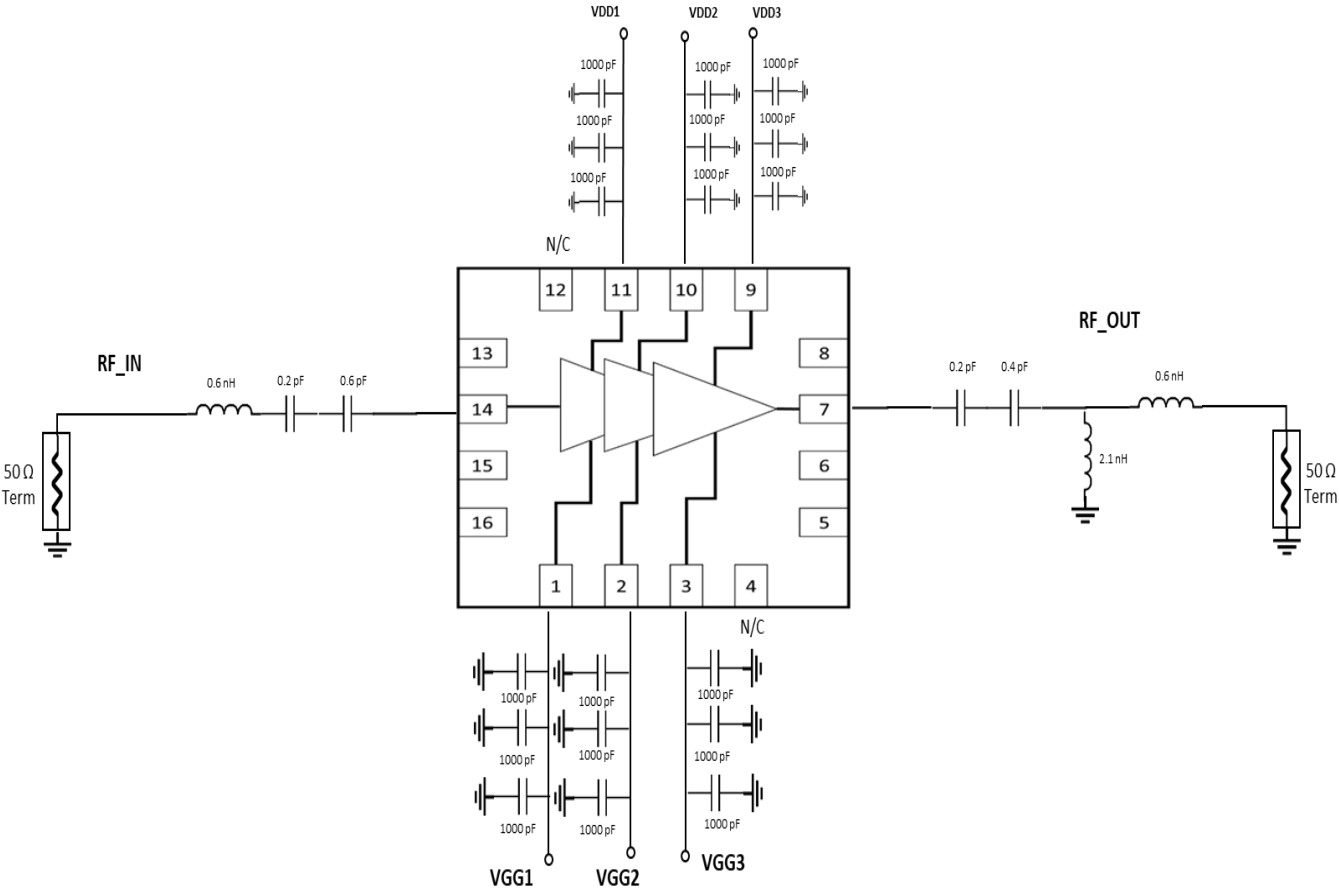

### Disclaimer:

Information in this document is provided in connection with Signify RF products. These materials are provided by Signify RF as a service to its customers and may be used for informational purposes only. Except as provided in Signify RF Terms and Conditions of Sale for such products or in any separate agreement related to this document, Signify RF assumes no liability whatsoever. Signify RF assumes no responsibility for errors or omissions in these materials. Signify RF may make changes to specifications and product descriptions at any time, without notice. Signify RF makes no commitment to update the information and shall have no responsibility whatsoever for conflicts or incompatibilities arising from future changes to its specifications and product descriptions. No license, express or implied, by estoppels or otherwise, to any intellectual property rights is granted by this document.

### Contact information:

For the latest specifications, additional product information:

Web: [www.signifyrf.com](http://www.signifyrf.com)

Email: [sales@signifyrf.com](mailto:sales@signifyrf.com)

Tel: (+1) 840 356 8957, (+91) 90220 78131, (+91) 84858 41789