

### Features:

- RF Frequency: 20 - 40 GHz
- Small signal gain: 19 dB
- Noise figure: 3.9 dB
- Output P1dB: 8.2 dBm
- Saturated Output Power: 15.3 dBm
- DC drain bias voltage: 4 V
- DC supply current: 78.8 mA
- 0.1um GaAs pHEMT Technology
- Die Size: 1.15 mm \* 1.45 mm

### Applications:

- Bluetooth
- Zigbee.
- SATCOM
- IoT
- Wi Fi

### Deliverables:

- Sample Ready Die
- Product Datasheet

### Functional Block Diagram:

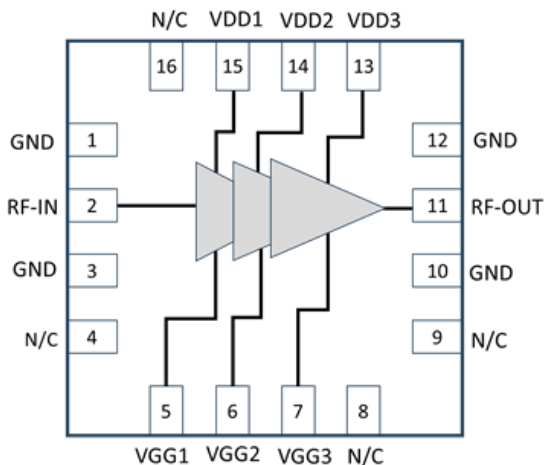

### Pin Configuration:

Pin No.	Pin Name	Description
1,3,10,12	GND	Ground
15	VDD1	Drain Bias Voltage 1
14	VDD2	Drain Bias Voltage 2
13	VDD3	Drain Bias Voltage 3
2	RF-IN	RF Input
11	RF-OUT	RF Output
5	VGG 1	Gate Bias Voltage 1
6	VGG 2	Gate Bias Voltage 2
7	VGG 3	Gate Bias Voltage 3
4,8,9,16	N/C	Not Connected

### Description:

RFLN40A\_B is a three-stage amplifier operating over the 20–40 GHz frequency range. The amplifier provides 18.9 dB of small-signal gain, with input and output matched to 50 Ω and on-chip DC blocking capacitors for ease of integration.

The device is designed for mmWave applications, including 5G infrastructure, SATCOM terminals, radar systems, point-to-point radio links, and other high-frequency wireless communication systems operating in the 20–40 GHz band.

The amplifier is designed using a 0.1 μm GaAs pHEMT process, enabling broadband performance across the entire operating frequency range.

Signify RF confidential property not to be copied or disclosed without prior authorization.

### Electrical Specification:

Freq= 20 - 40 GHz, VDD1=VDD2=VDD3= 4V, VGG1=VGG2=VGG3= -0.5V ID= 78.8 mA, Zo=50 Ω

Parameters	Test Condition	Units	Typ
Gain	20 GHz	dB	17
	30 GHz		19
	40 GHz		20
Output P1 dB	20 GHz	dBm	-
	30 GHz		8.2
	40 GHz		-
OIP3 Pin= 1 dBm Δf = 50MHz	20 GHz	dBm	-
	30 GHz		17.6
	40 GHz		-
Noise Figure	20 GHz	dB	3.8
	30 GHz		3.9
	40 GHz		4.1
Input Return Loss	20 GHz	dB	6
	30 GHz		2.9
	40 GHz		5
Output Return Loss	20 GHz	dB	9.9
	30 GHz		2.7
	40 GHz		7
Drain Current (Id)	-	mA	78.8
Drain Voltage (VDD)	-	V	4
Gate Voltage (VGG)	-	V	-0.5

# Low Noise Amplifier

## PRODUCT DATASHEET RFLN40A\_B

### Typical Performance Curves:

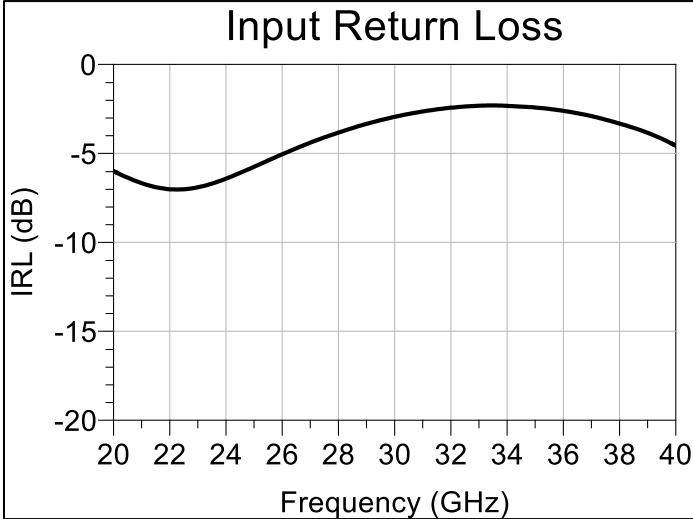
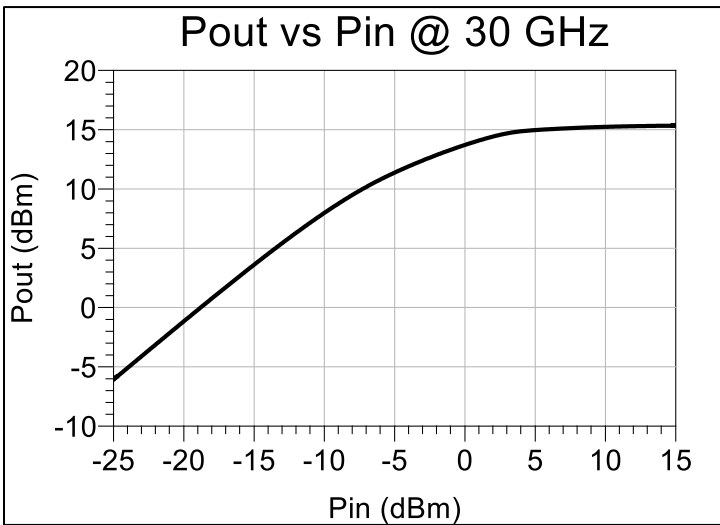
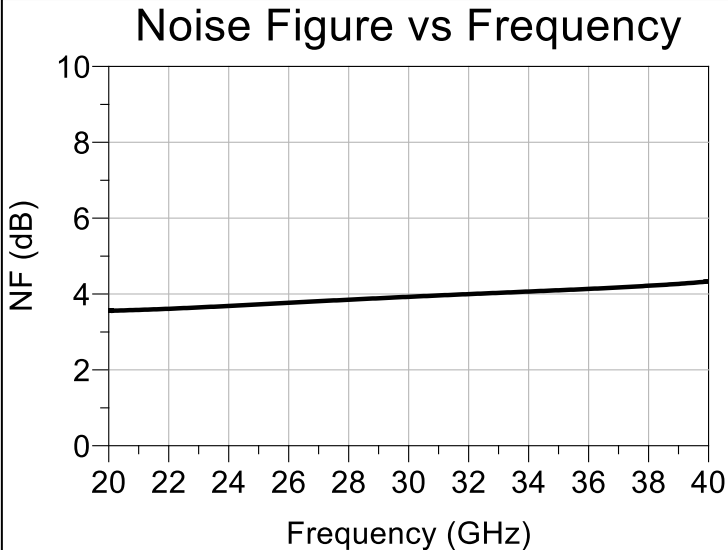
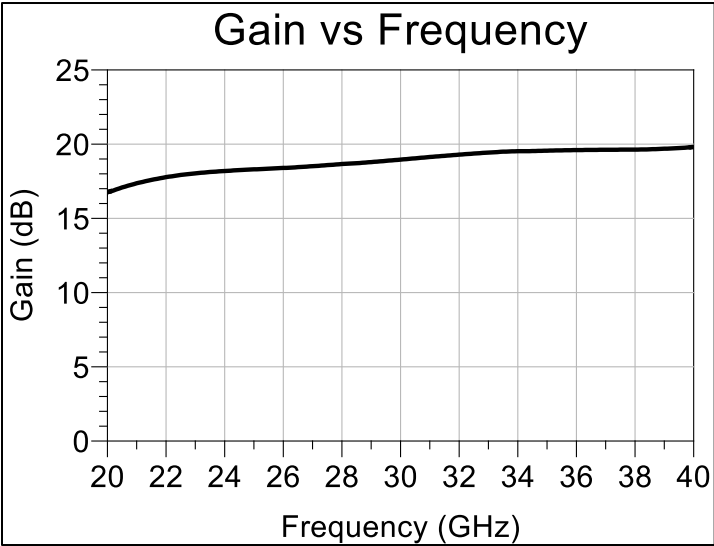

# Low Noise Amplifier



## PRODUCT DATASHEET

## RFLN40A\_B

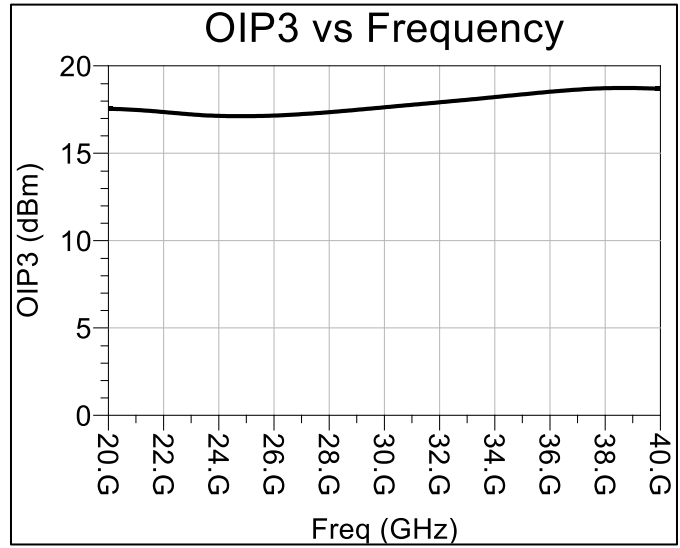
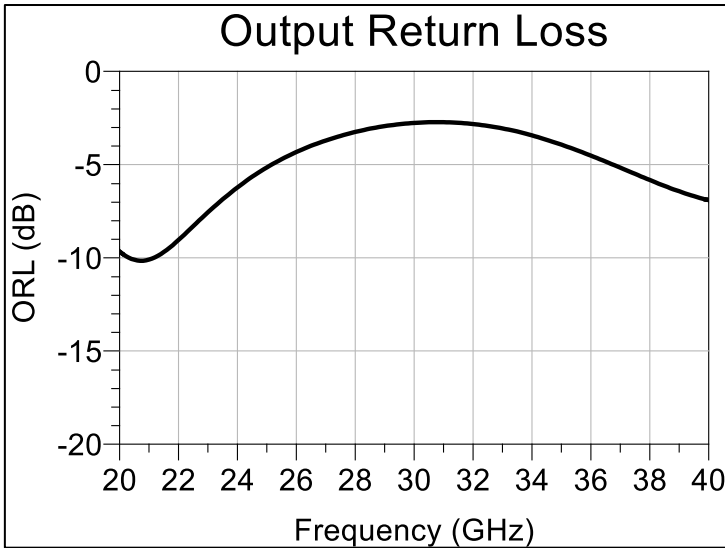

Signify RF confidential property not to be copied or disclosed without prior authorization.

[www.signifyrf.com](http://www.signifyrf.com)

June 2026

### Disclaimer:

Information in this document is provided in connection with Signify RF products. These materials are provided by Signify RF as a service to its customers and may be used for informational purposes only. Except as provided in Signify RF Terms and Conditions of Sale for such products or in any separate agreement related to this document, Signify RF assumes no liability whatsoever. Signify RF assumes no responsibility for errors or omissions in these materials. Signify RF may make changes to specifications and product descriptions at any time, without notice. Signify RF makes no commitment to update the information and shall have no responsibility whatsoever for conflicts or incompatibilities arising from future changes to its specifications and product descriptions. No license, express or implied, by estoppel or otherwise, to any intellectual property rights is granted by this document.

### Contact information:

For the latest specifications, additional product information

Web: [www.signifyrf.com](http://www.signifyrf.com)

Email: [sales@signifyrf.com](mailto:sales@signifyrf.com)

Tel: (+1) 840 356 8957, (+91) 90220 78131, (+91) 84858 41789