

### Features:

- RF Frequency: DC - 20 GHz
- Small signal gain: 14 dB
- Output P1dB: 5.8 dBm
- Saturated Output Power: 10.93 dBm
- DC drain bias voltage: 5 V
- DC supply current: 50 mA
- DC Gate Bias Voltage: -0.5 V
- 0.1um GaAs pHEMT Technology
- Die Size: 1.15 mm \* 1.45 mm

### Applications:

- Broadband RF and microwave signal amplification
- Test and measurement systems
- Communication system front-ends
- Radar and electronic warfare (EW) systems
- Signal conditioning in high-frequency circuits

### Deliverables:

- Sample Ready Die
- Product Datasheet

### Functional Block Diagram:

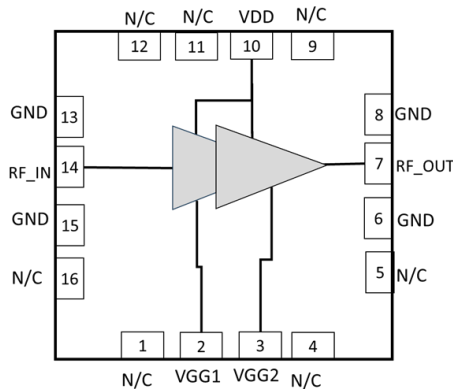

### Pin Configuration:

Pin No.	Pin Name	Description
1,4,5,9,11,12,16	N/C	Not Connected
6,8,13,15	GND	Ground
2	VGG1	Gate Bias Voltage 1
3	VGG2	Gate Bias Voltage 2
10	VDD	Drain Bias Voltage
14	RF-IN	RF Input
7	RF-OUT	RF Output

### Description:

RFDCA20 is a broadband Direct Coupled Amplifier designed for operation from DC to 20 GHz. The amplifier provides good small-signal gain with input and output matched to 50 Ω.

The wideband frequency coverage makes the device suitable for a broad range of RF, microwave, instrumentation, communication, and SATCOM applications requiring moderate gain over an extended frequency range.

The amplifier is fabricated using a 0.1 μm GaAs pHEMT process. The results presented in this datasheet include all relevant parasitic and coupling effects at the specified frequencies.

### Electrical Specification:

Freq= DC - 20GHz, VDD= 5V, VGG1=VGG2= -0.5 V, ID= 50 mA, Zo=50  $\Omega$

Parameters	Test Condition	Units	Typ
Gain	DC	dB	9.2
	10 GHz		14
	20 GHz		10
Output P1 dB	DC	dBm	
	10 GHz		5.8
	20 GHz		
OIP3 Pin= 1 dBm $\Delta f = 50\text{MHz}$	DC	dBm	
	10 GHz		13.2
	20 GHz		
Input Return Loss	DC	dB	0.7
	10 GHz		3
	20 GHz		4.7
Output Return Loss	DC	dB	22.5
	10 GHz		13.5
	20 GHz		7
<b>Operating Bias Conditions</b>			
Drain Current (Id)	-	mA	50
Drain Voltage (VDD)	-	V	5
Gate Voltage (VGG)	-	V	-0.5

### On- Wafer Measured Data Performance Curve:

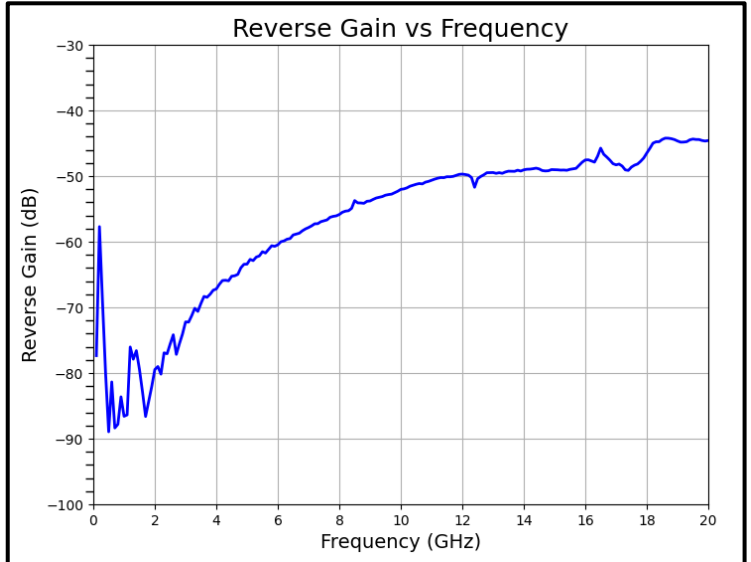
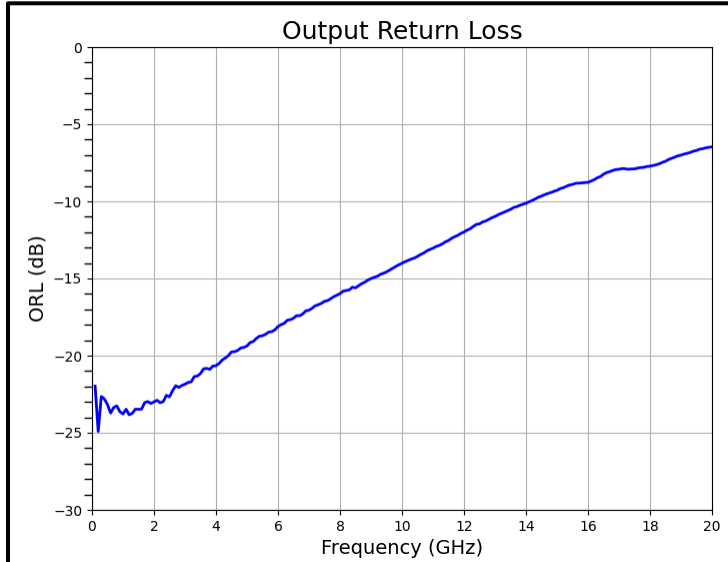
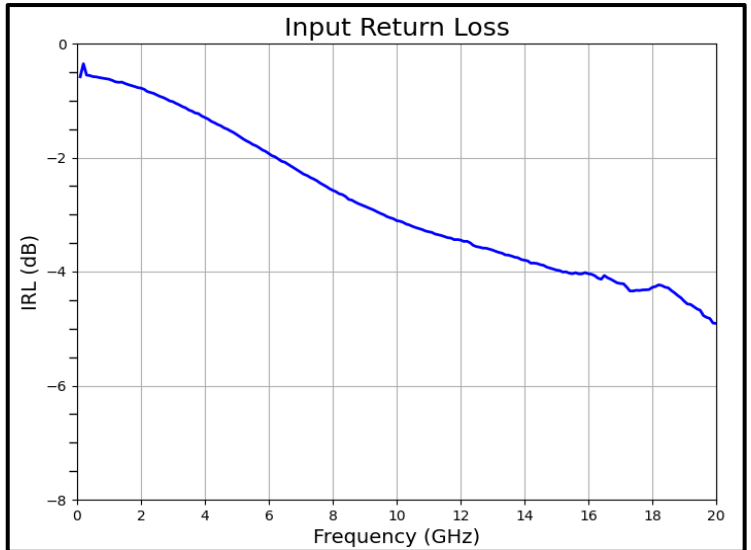
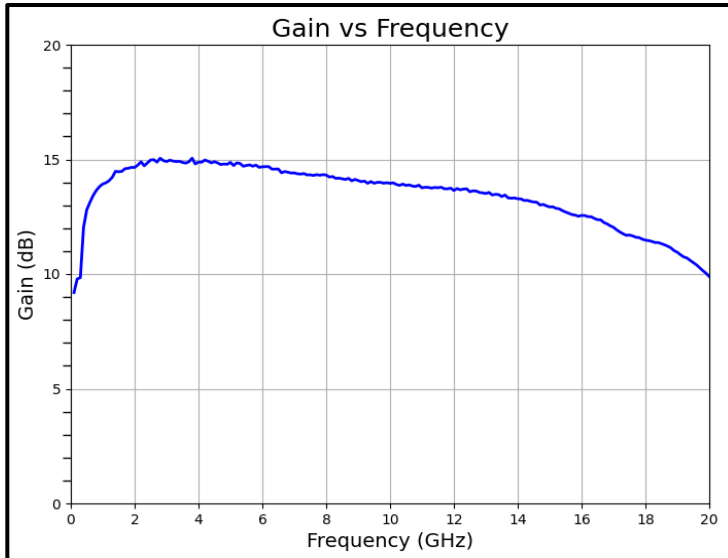

# Direct Couple Amplifier



## PRODUCT DATASHEET

## RFDA20

### Typical Performance Curves:

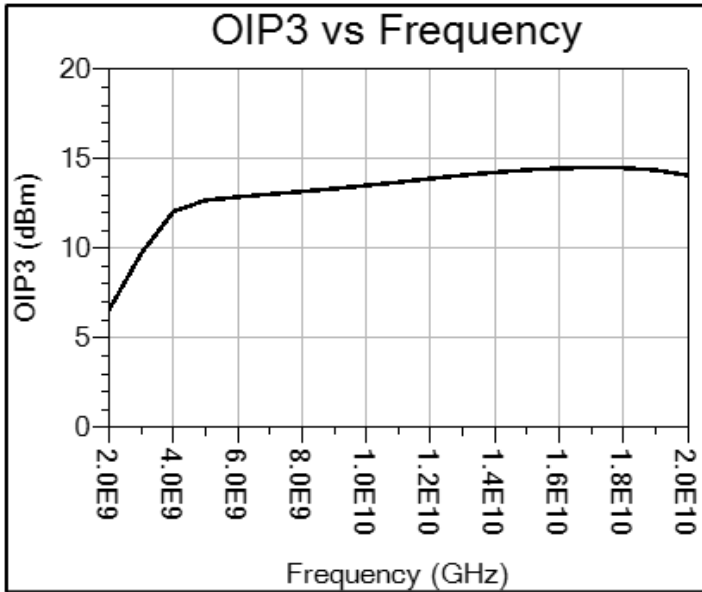
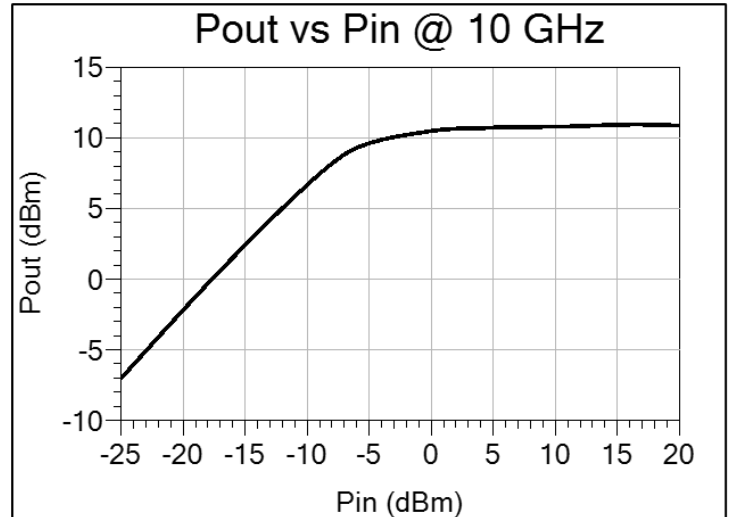
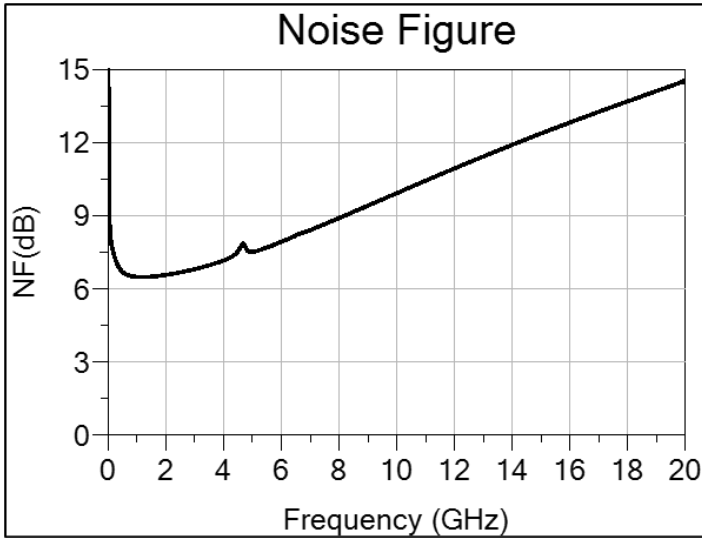

Signify RF confidential property not to be copied or disclosed without prior authorization.

[www.signifyrf.com](http://www.signifyrf.com)

June 2026

### Application Diagram:

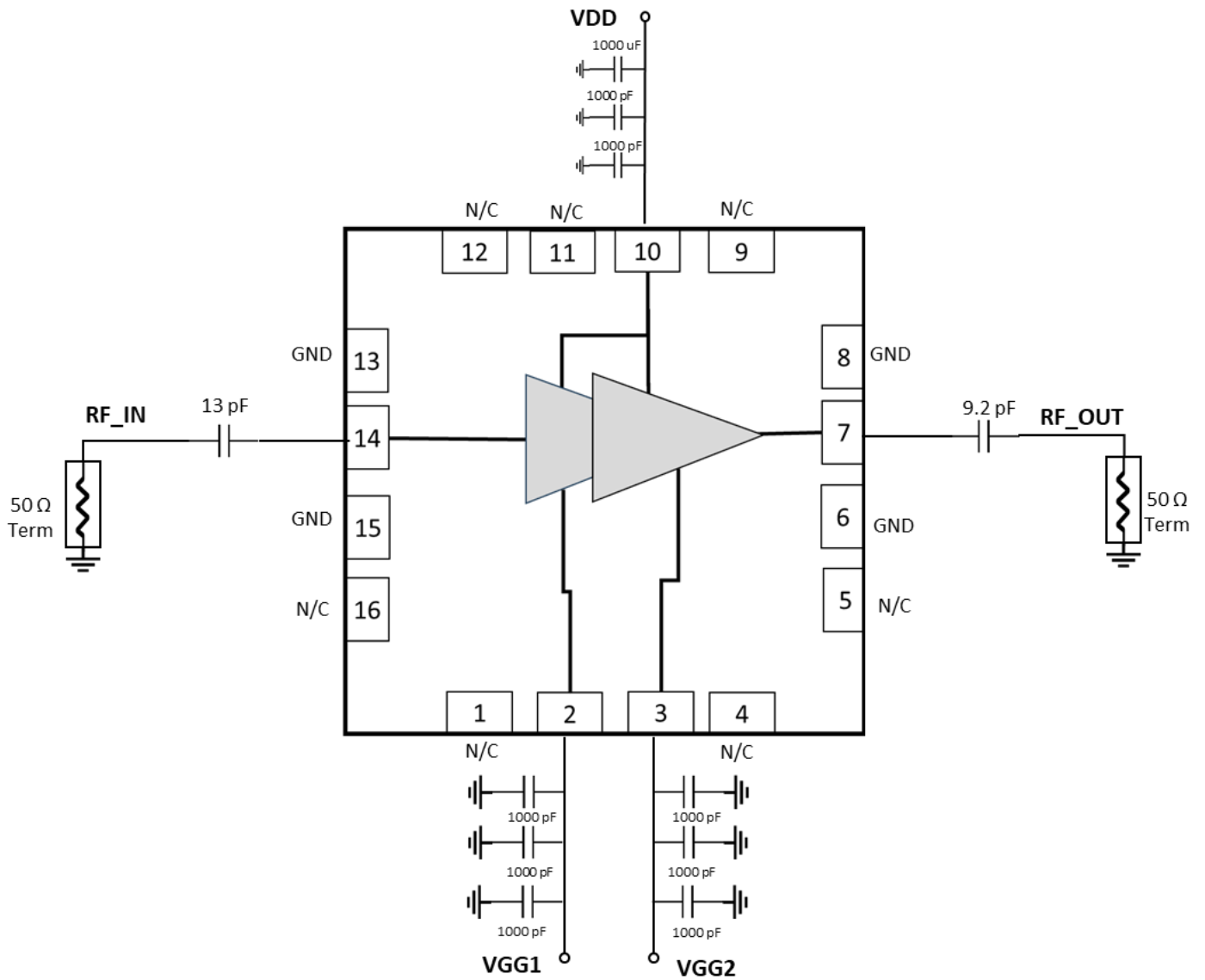

### Disclaimer:

Information in this document is provided in connection with Signify RF products. These materials are provided by Signify RF as a service to its customers and may be used for informational purposes only. Except as provided in Signify RF Terms and Conditions of Sale for such products or in any separate agreement related to this document, Signify RF assumes no liability whatsoever. Signify RF assumes no responsibility for errors or omissions in these materials. Signify RF may make changes to specifications and product descriptions at any time, without notice. Signify RF makes no commitment to update the information and shall have no responsibility whatsoever for conflicts or incompatibilities arising from future changes to its specifications and product descriptions. No license, express or implied, by estoppel or otherwise, to any intellectual property rights is granted by this document.

### Contact information:

For the latest specifications, additional product information:

Web: [www.signifyrf.com](http://www.signifyrf.com)

Email: [sales@signifyrf.com](mailto:sales@signifyrf.com)

Tel: (+1) 840 356 8957, (+91) 90220 78131, (+91) 84858 41789