

### Direct Coupled Amplifier:

- RF Frequency: DC- 12 GHz
- Small signal gain: 8.5 dB
- Output P1dB: 6 dBm
- Saturated Output Power: 7 dBm
- DC drain bias voltage: 4 V
- Dc supply current: 58.9 mA
- 0.1um GaAs pHEMT Technology
- Die Size: 1.15 mm \* 1.02 mm

### Functional Block Diagram

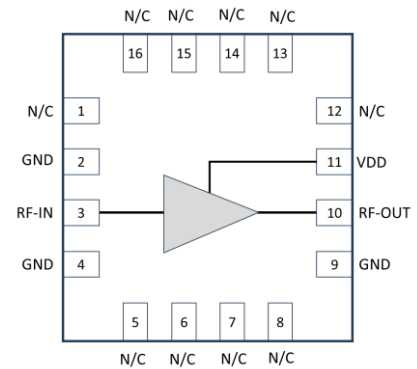

### Description:

RFDCA06S is a Direct Coupled Amplifiers that operates from DC to 12 GHz. The amplifier provides 8.5 dB of small signal gain.

The RFDCA06S device is specifically designed for use in the DC-12 GHz frequency range in Bluetooth, Zigbee, Wi-Fi, IoT, and SATCOM applications.

The Technology used to design DCA is a 0.1um GaAs pHEMT Process.

### Pin Configuration

Pin No.	Pin Name	Description
2,4,9	GND	Ground
3	RF-IN	RF Input
10	RF-OUT	RF Output
1,5,6,7,8,12,13,14,15,16	N/C	Not Connected
11	VDD	Voltage Drain Bias

### Applications:

- Mobile Phones
- GPS
- Weather radar
- Long Distance radio telecommunications
- Military telemetry
- Communications

### Deliverables:

- Sample Ready Die
- Product Datasheet

### Electrical Specification:

Freq = DC-12 GHz, VDD= 4V, ID= 58.9 mA, Zo=50 Ω

Parameters	Test Condition	Units	Typ
Gain	DC	dB	15
	6 GHz		8.5
	12 GHz		9.4
Output P1 dB	DC	dBm	
	6 GHz		6
	12 GHz		
Noise Figure	DC	dB	7.5
	6 GHz		11
	12 GHz		10
Input Return Loss	DC	dB	1.7
	6 GHz		3.8
	12 GHz		2.5
Output Return Loss	DC	dB	8
	6 GHz		9
	12 GHz		8.5
<b>Operating Bias Conditions</b>			
Drain Current (Id)	-	mA	58.9
Drain Voltage (VDD)	-	V	4

### Typical Performance Curve:

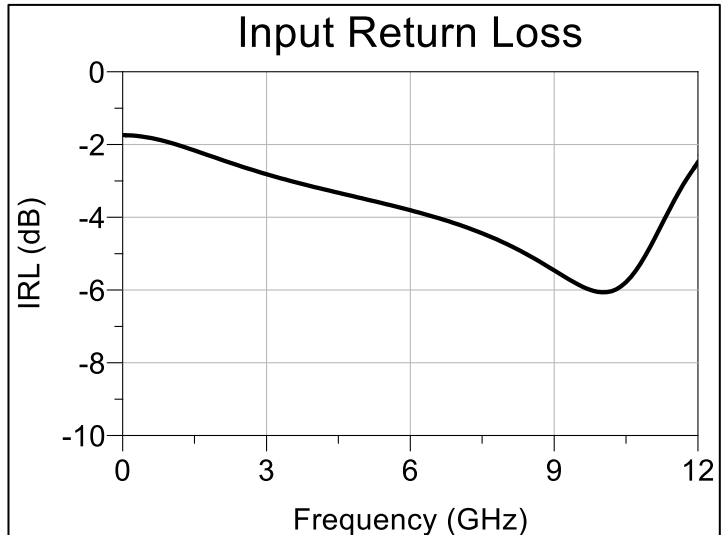
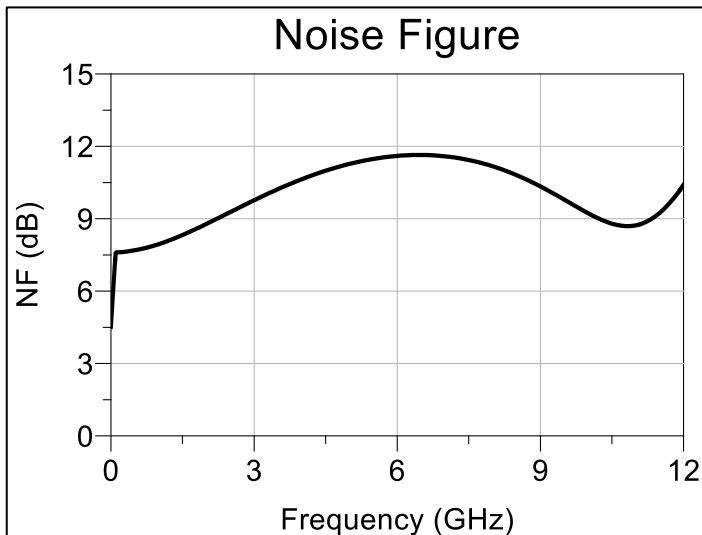
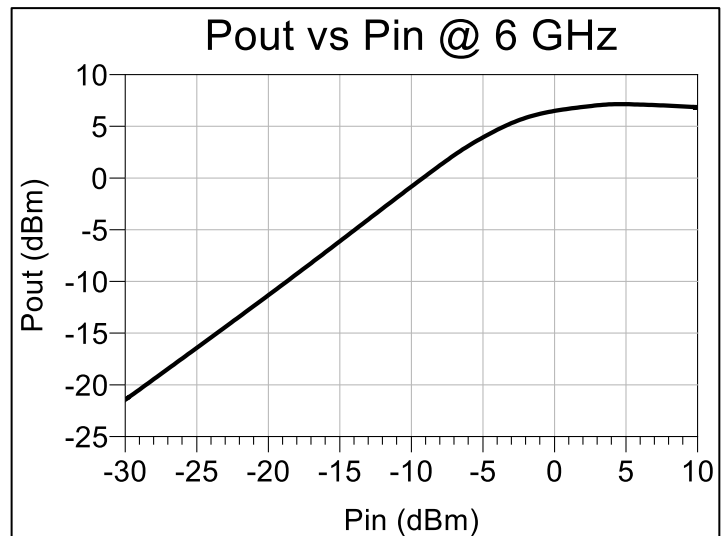
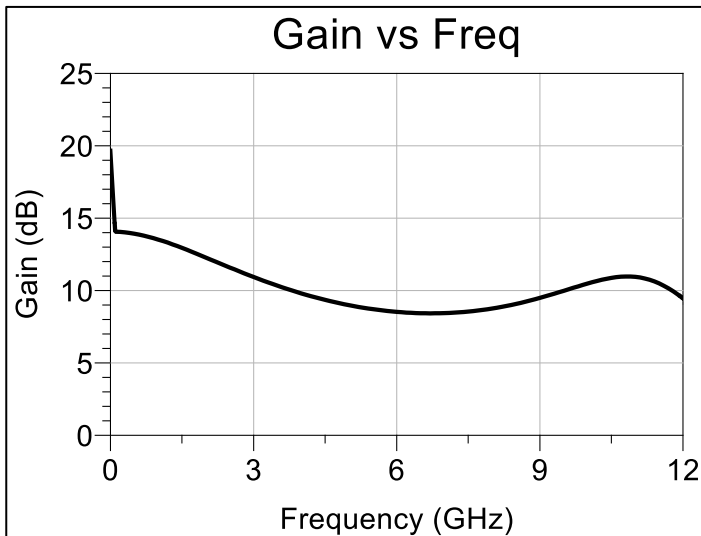

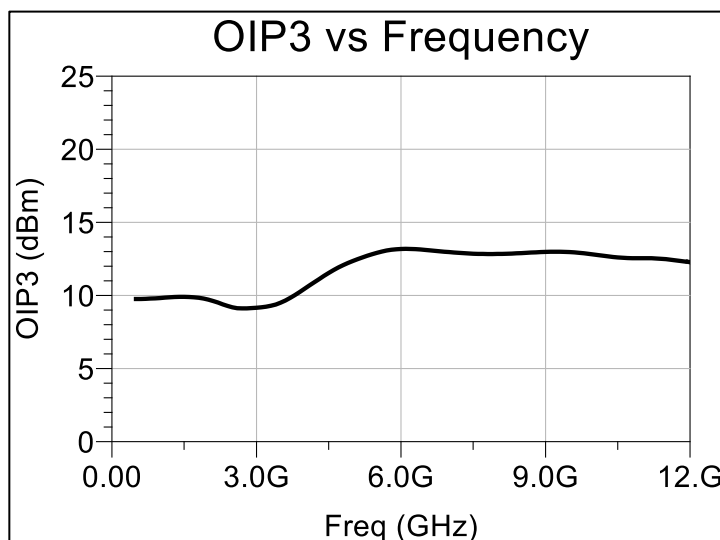
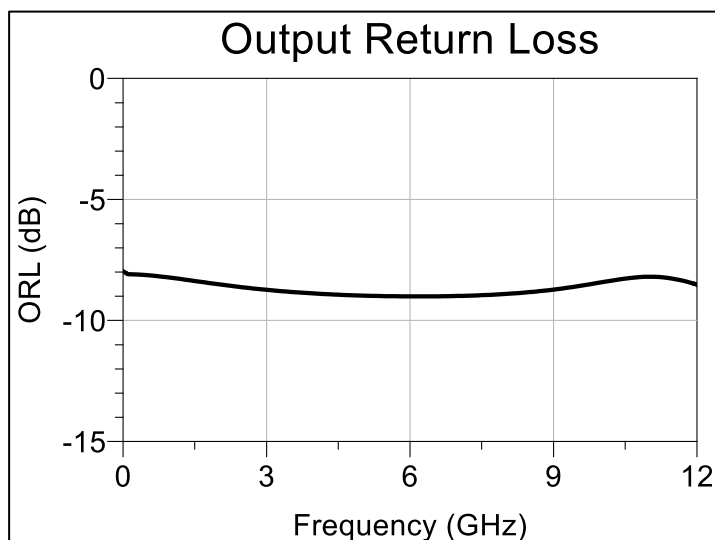

### Disclaimer:

Information in this document is provided in connection with Signify RF products. These materials are provided by Signify RF as a service to its customers and may be used for informational purposes only. Except as provided in Signify RF Terms and Conditions of Sale for such products or in any separate agreement related to this document, Signify RF assumes no liability whatsoever. Signify RF assumes no responsibility for errors or omissions in these materials. Signify RF may make changes to specifications and product descriptions at any time, without notice. Signify RF makes no commitment to update the information and shall have no responsibility whatsoever for conflicts or incompatibilities arising from future changes to its specifications and product descriptions. No license, express or implied, by estoppels or otherwise, to any intellectual property rights is granted by this document.

### Contact information

For the latest specifications, additional product information:

Web: [www.signifyrf.com](http://www.signifyrf.com)

Email: [sales@signifyrf.com](mailto:sales@signifyrf.com)

Tel: (+91) 840 356 8957, (+91)9022078131, (+91)8485841789