

Features:

- RF Frequency: 12-18 GHz
- Conversion gain: 4 dB
- Input return loss:15 dB
- DC drain bias voltage:8
- DC Current :17.3
- 0.1 um GaAS pHEMT Technology

Functional Block Diagram

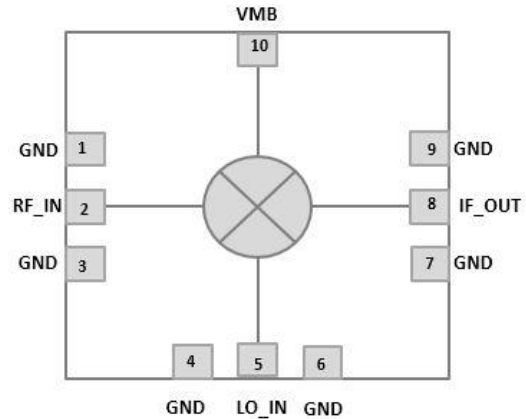

Description

RFDBDN12 (DNC Mixer) is IR SSB Mixer used in receive application. The process used to design DNC Mixer is 0.1um GaAs pHEMT.

This Mixer employs two resistive FET switches to mix LO and RF. In a resistive FET mixer, where the LO of the mixer is applied to the gate. RF is applied to the drain and, consequently, IF is filtered from the drain. No drain dc-bias voltage is applied to the transistor. Gate bias can help us achieve better linearity, minimum conversion loss with less LO power over the wideband down conversion operation.

Pin Configuration

Pin No.	Pin Name	Description
1	GND	RF Ground
2	RF_IN	RF Input
3	GND	RF Ground
4	GND	RF Ground
5	LO_IN	LO Input
6	GND	RF Ground
7	GND	RF Ground
8	IF_OUT	IF output
9	GND	RF Ground
10	VMB	Mixer Bias

Application:

- Satellite Communication
- Point-to-point communication system
- 5G RF transceiver
- Radar

Deliverables:

- Sample Ready Die
- Product Datasheet

Electrical Specification: The electrical specifications apply at TA=+25°C in a 50Ω system. Typical data shown is for a down conversion application with a +17dBm sine wave LO input and a mixer bias of -1 V.

Parameter	Min	Typ	Max	Unit
RF (Port 1) Frequency Range	8		12	GHz
LO (Port 2) Frequency Range		0.1		GHz
IF (Port 3) Frequency Range	7.9		11.9	GHz
Conversion Gain (CG)		4		dB
Input Return Loss		15		dB
Output P1dB		2		dBm
DC Drain Bias Voltage		10		V
DC Gate Bias Voltage		0.5		V
DC Current Total		9.35		mA

Typical Performance Plots: The test conditions and frequency plan below applies to all following sections, unless otherwise specified.

Frequency spacing = 100 MHz ,VMB (Mixer bias) = -0.5 V

RF Port Return Loss

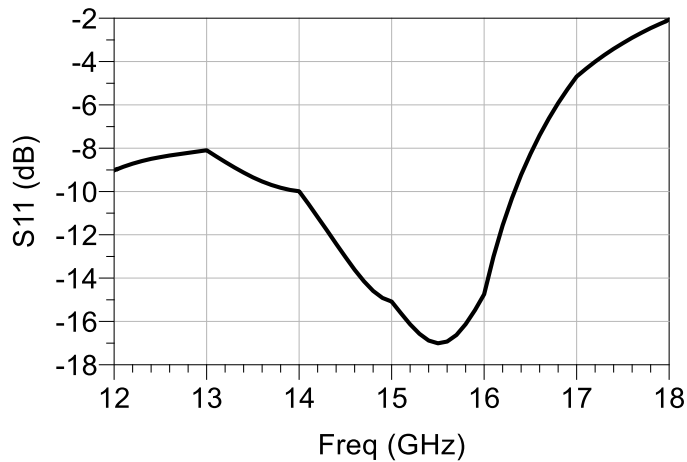

LO Port Return Loss

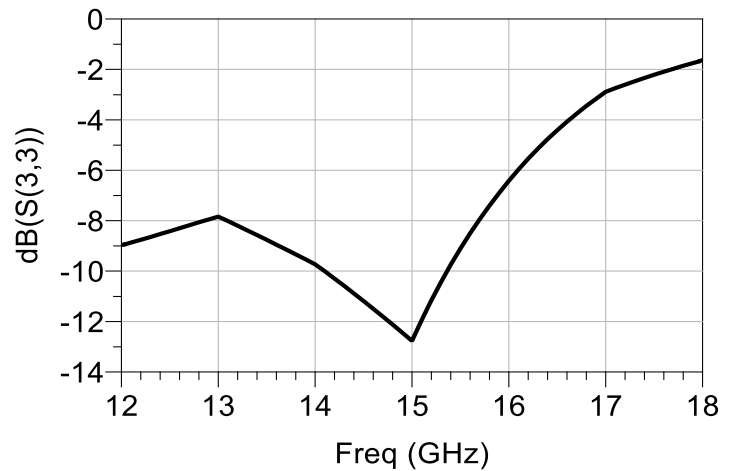

Conversion Gain vs Rf Frequency

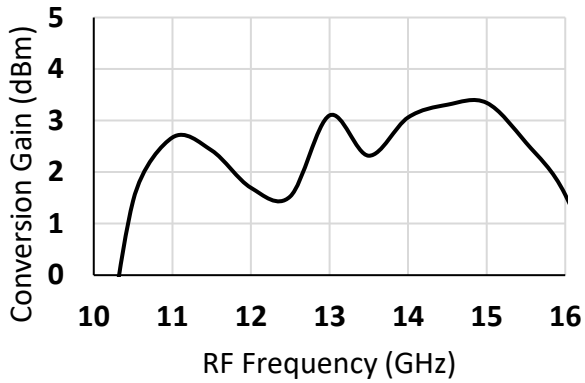

Conversion Gain vs. Available Source Power

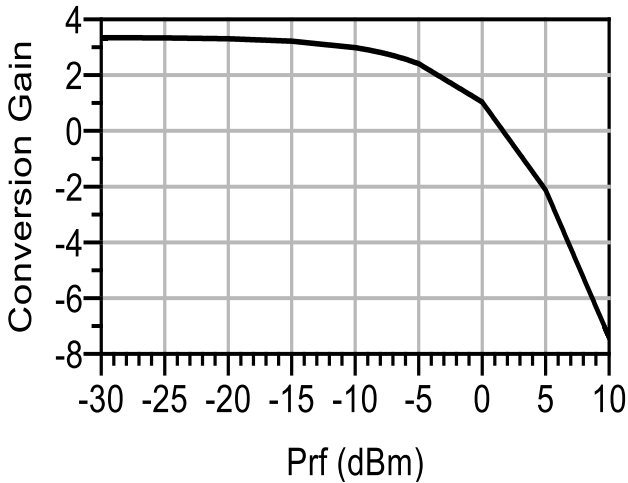

Output power delivered to load

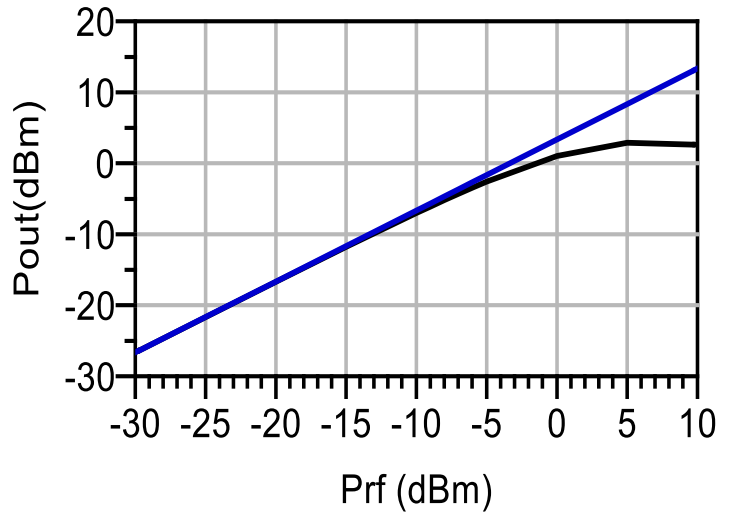

Disclaimer

Information in this document is provided in connection with Signify RF products. These materials are provided by Signify RF as a service to its customers and may be used for informational purposes only. Except as provided in Signify RF Terms and Conditions of Sale for such products or in any separate agreement related to this document, Signify RF assumes no liability whatsoever. Signify RF assumes no responsibility for errors or omissions in these materials. Signify RF may make changes to specifications and product descriptions at any time, without notice. Signify RF makes no commitment to update the information and shall have no responsibility whatsoever for conflicts or incompatibilities arising from future changes to its specifications and product descriptions. No license, express or implied, by estoppel or otherwise, to any intellectual property rights is granted by this document.

Contact information

For the latest specifications and additional product information:

Web: www.signifyrf.com

Email: sales@signifyrf.com

Tel: (+1) 840 356 8957, (+91) 90220 78131, (+91) 84858 41789