

### Features:

- RF Frequency: DC to 26 GHz
- Small signal gain: 15.7 dB
- Input return loss: 15 dB
- Output return loss: 15.7 dB
- Noise figure: 2.3 dB
- Output P1 dB: 11.65 dBm
- Saturated output power: 19 dBm
- DC drain bias voltage: 4 V
- Dc supply current: 110 mA
- 100 nm GaAs pHEMT Technology.
- Die Size: 0.9mm \* 2.6mm

### Applications:

- GPS
- Weather radar
- Satellite communications
- Radar
- Automotive radar
- Astronomical observations
- Long-distance radio telecommunications

### Deliverables:

- Sample Ready Die
- Product Datasheet

### Functional Block Diagram:

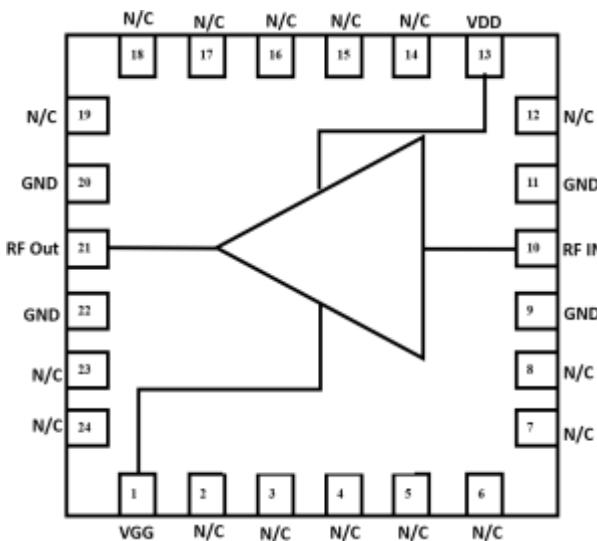

### Pin Configuration:

Pin No.	Pin Name	Description
9,11,20,22	GND	RF Ground
10	RF_IN	RF Input
21	RF_OUT	RF Output
13	VDD	Drain Bias Voltage
1	VGG	Gate Bias Voltage
2,3,4,5,6,7,8,12,14,15,16,17,18,19,23,24	N/C	Not Connected

### Description:

The RFDBA26 is a wideband GaAs MMIC distributed amplifier designed using 0.1  $\mu\text{m}$  GaAs pHEMT technology, operating from DC to 26 GHz. The amplifier provides 15.7 dB small-signal gain, with a corresponding output 1 dB compression point (P1dB) of 11.65 dBm and a noise figure of 2.3 dB at 13 GHz.

The presented results include all parasitic and coupling effects at the desired operating frequencies.

### Electrical Specification:

Freq=DC-26 GHz, VDD =4V, VGG = -0.4V, ID= 110mA, Zo=50 Ω

Parameters	Test Condition	Units	Typ
Gain	500 MHz	dB	15.1
	13 GHz		15.7
	26GHz		16
Output P1 dBm Pin= -1 dBm	500 MHz	dBm	
	13 GHz		11.65
	26GHz		
OIP3 Pin= -10 dBm Δf = 50MHz	500 MHz	dBm	
	13 GHz		20.95
	26GHz		
Noise Figure	500 MHz	dB	6.4
	13 GHz		2.3
	26GHz		5
Input Return Loss	500 MHz	dB	6.7
	13 GHz		15
	26GHz		6
Output Return Loss	500 MHz	dB	10.1
	13 GHz		15.7
	26GHz		9
<b>Operating Bias Conditions</b>			
Drain Current (Id)	-	mA	110
Drain Voltage (VDD)		V	4
Gate Voltage (VGG)	-	V	-0.4

# Distributed Amplifier

## PRODUCT DATASHEET

## RFDBA26

### Typical Performance Curves:

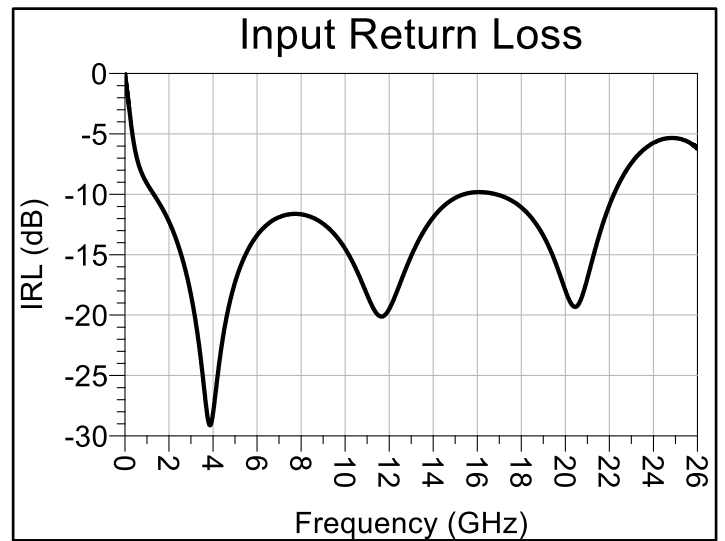
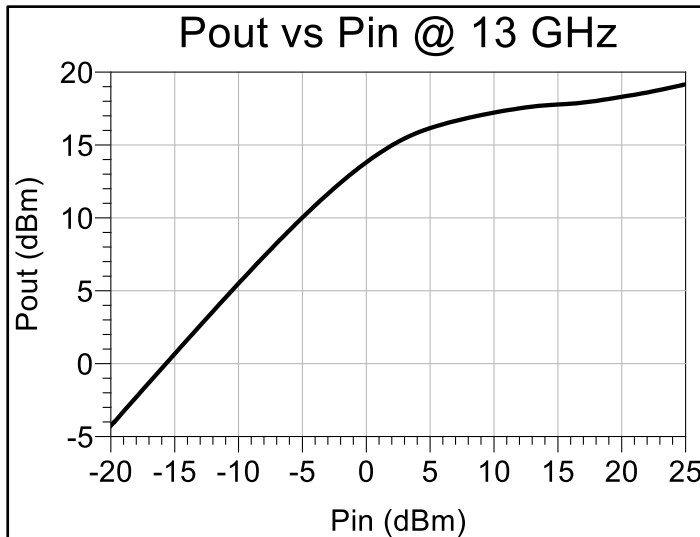
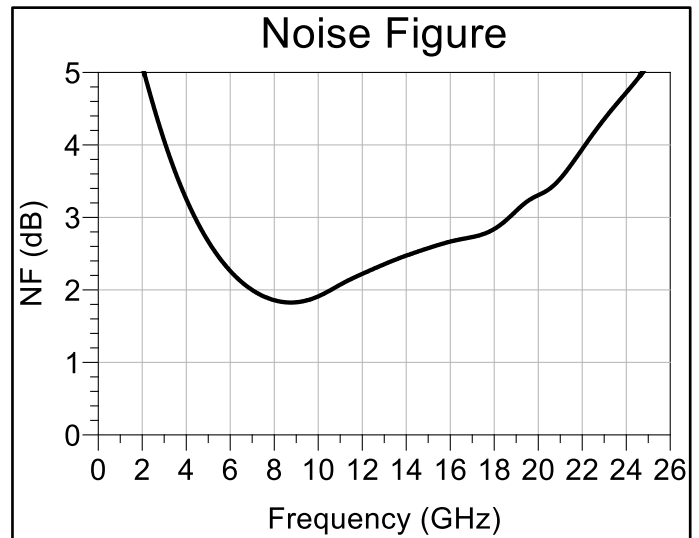
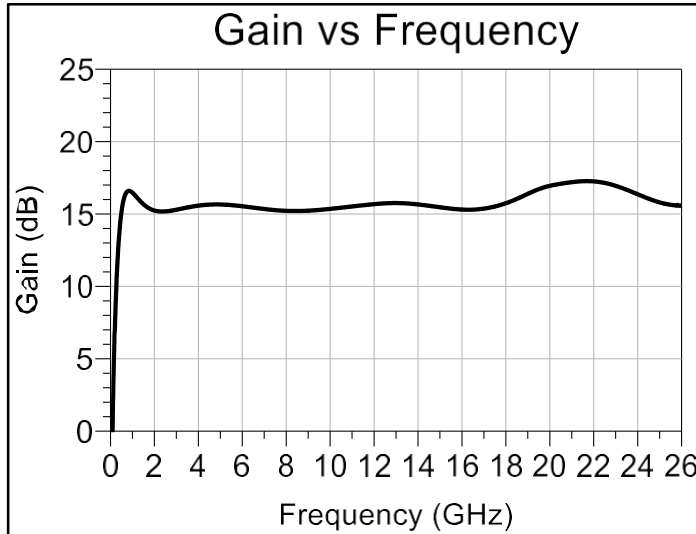

# Distributed Amplifier

## PRODUCT DATASHEET

## RFDBA26

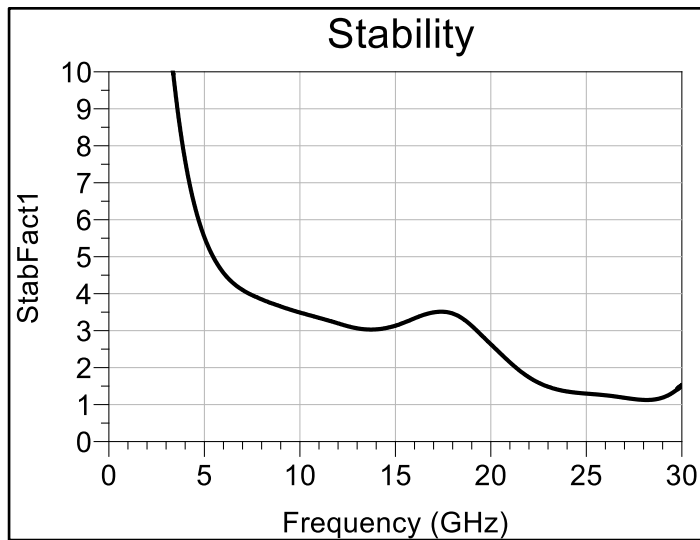
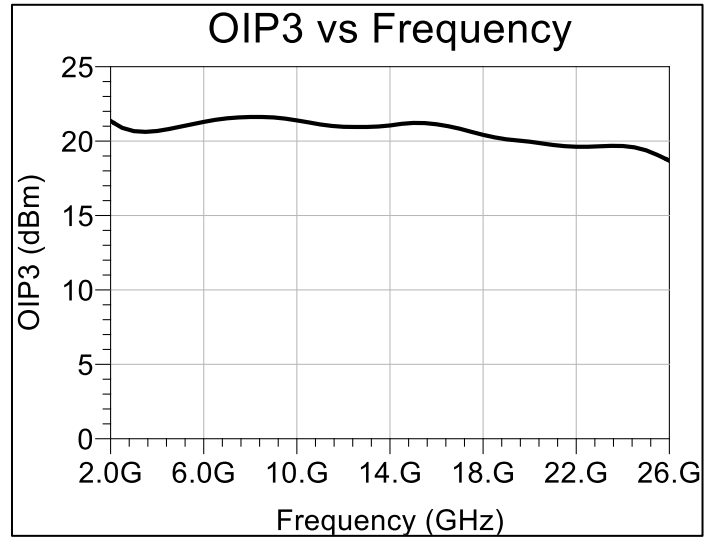
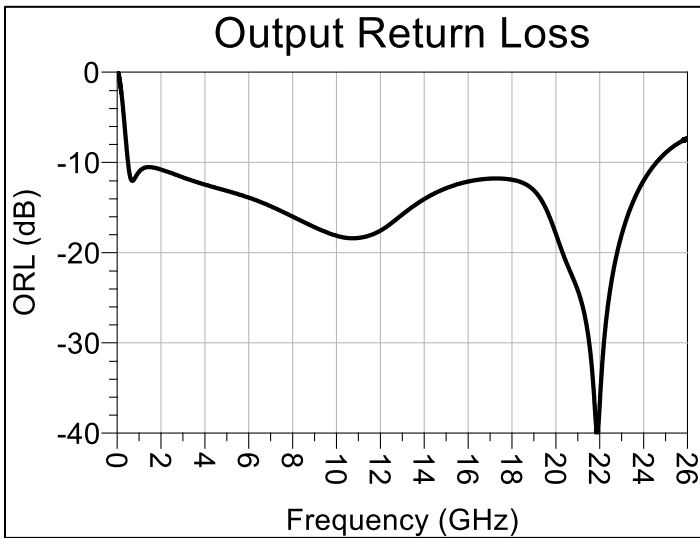

# Distributed Amplifier

## PRODUCT DATASHEET

## RFDBA26

### Application Diagram:

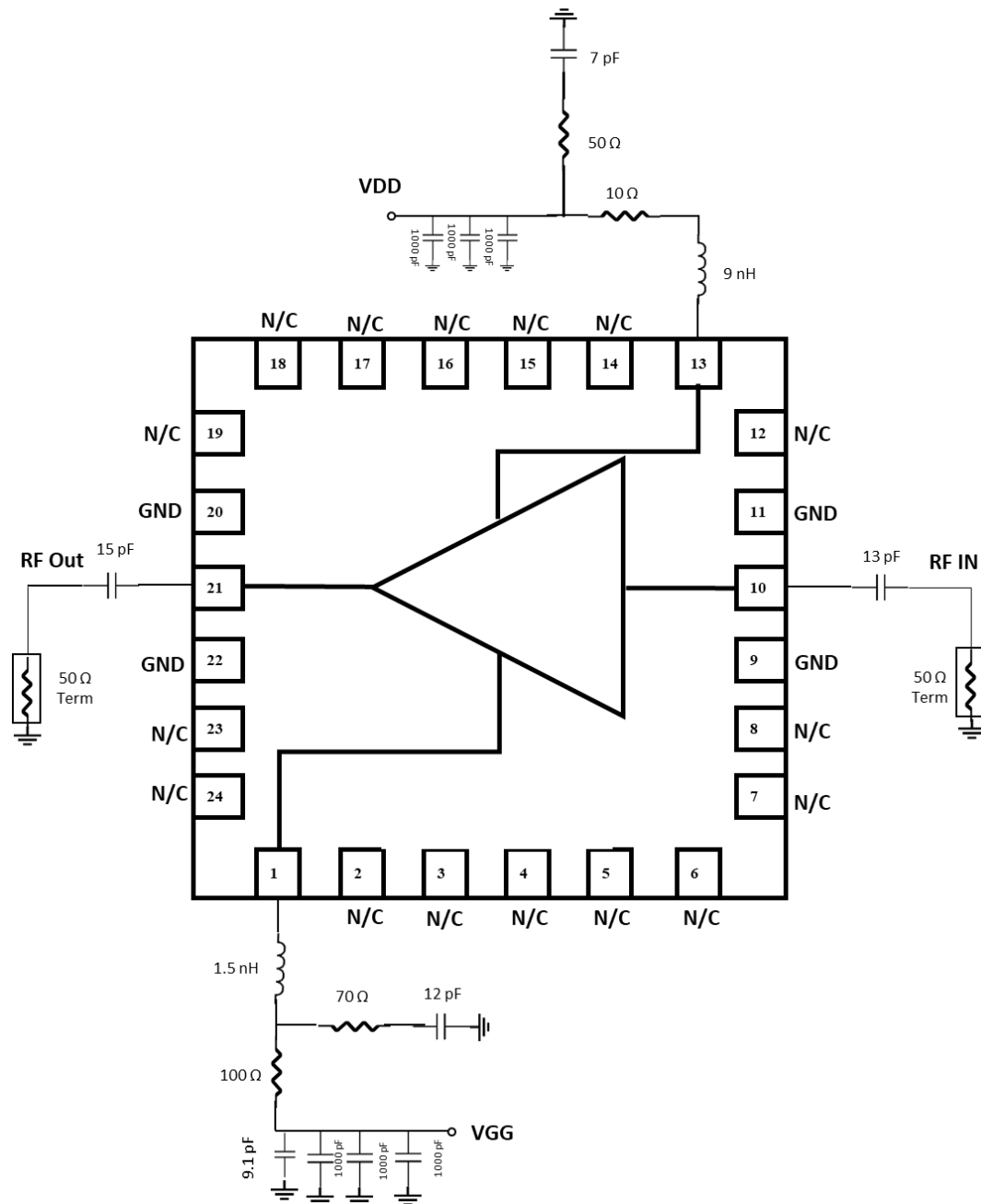

Signify RF confidential property not to be copied or disclosed without prior authorization.

### Disclaimer:

Information in this document is provided in connection with Signify RF products. These materials are provided by Signify RF as a service to its customers and may be used for informational purposes only. Except as provided in Signify RF Terms and Conditions of Sale for such products or in any separate agreement related to this document, Signify RF assumes no liability whatsoever. Signify RF assumes no responsibility for errors or omissions in these materials. Signify RF may make changes to specifications and product descriptions at any time, without notice. Signify RF makes no commitment to update the information and shall have no responsibility whatsoever for conflicts or incompatibilities arising from future changes to its specifications and product descriptions. No license, express or implied, by estoppels or otherwise, to any intellectual property rights is granted by this document.

### Contact information:

For the latest specifications, additional product information:

Web: [www.signifyrf.com](http://www.signifyrf.com)

Email: [sales@signifyrf.com](mailto:sales@signifyrf.com)

Tel: (+1) 840 356 8957, (+91) 9922781815, (+91) 8485841789