

### Features:

- RF Frequency: 2-6 GHz
- Small signal gain: 24.8 dB
- Output P1dB: 23.5 dBm
- Saturated Output Power: 30 dBm
- DC drain bias voltage: 5V
- DC supply current: 110 mA
- DC Gate Bias Voltage: -0.5V
- 0.1um GaAs pHEMT Technology
- Die Size: 0.9 mm \* 1.45 mm

### Applications:

- Wireless Communication System
- SATCOM
- RADAR
- Aerospace & Defense Systems

### Deliverables:

- Sample Ready Die
- Product Datasheet

### Functional Block Diagram:

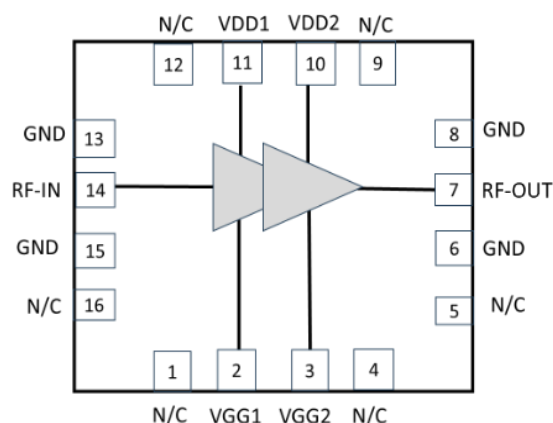

### Pin Configuration:

Pin No.	Pin Name	Description
1,4,5,9,12,16	N/C	Not Connected
6,8,13,15	GND	Ground
2	VGG1	Gate Bias Voltage 1
3	VGG2	Gate Bias Voltage 2
11	VDD 1	Drain Bias Voltage 1
10	VDD 2	Drain Bias Voltage 2
14	RF-IN	RF Input
7	RF-OUT	RF Output

### Description:

RFDA06 is a two-stage driver amplifier designed for operation in the 2-6 GHz frequency range and intended for driving high-power amplifiers.

Although optimized for 2-6 GHz operation, wafer-level measurement results demonstrate useful gain performance up to 12 GHz, enabling its use in higher-frequency RF and microwave applications.

The amplifier is fabricated using a 0.1  $\mu\text{m}$  GaAs pHEMT process. The results presented in this datasheet include all relevant parasitic and coupling effects at the specified frequencies.

### Electrical Specification:

Freq= 2 - 6 GHz, VDD1=VDD2= 5V, VGG1=VGG2= -0.5 V, ID= 110 mA, Zo=50  $\Omega$

Parameters	Test Condition	Units	Typ
Gain	2 GHz	dB	19.8
	4 GHz		24.8
	6 GHz		19.8
Output P1 dB	2 GHz	dBm	
	4 GHz		23.5
	6 GHz		
OIP3 Pin= 1 dBm $\Delta f = 50\text{MHz}$	2 GHz	dBm	
	4 GHz		30.9
	6 GHz		
Noise Figure	2 GHz	dB	
	4 GHz		1.5
	6 GHz		
Input Return Loss	2 GHz	dB	9
	4 GHz		19
	6 GHz		8
Output Return Loss	2 GHz	dB	12
	4 GHz		19
	6 GHz		14.8
<b>Operating Bias Conditions</b>			
Drain Current (Id)	-	mA	110
Drain Voltage (VDD)	-	V	5
Gate Voltage (VGG)	-	V	-0.5

### Wafer Level Measured Results:

Freq= 2 - 12 GHz, VDD1=VDD2= 5V, VGG1=VGG2= -0.3 V, ID= 60 mA

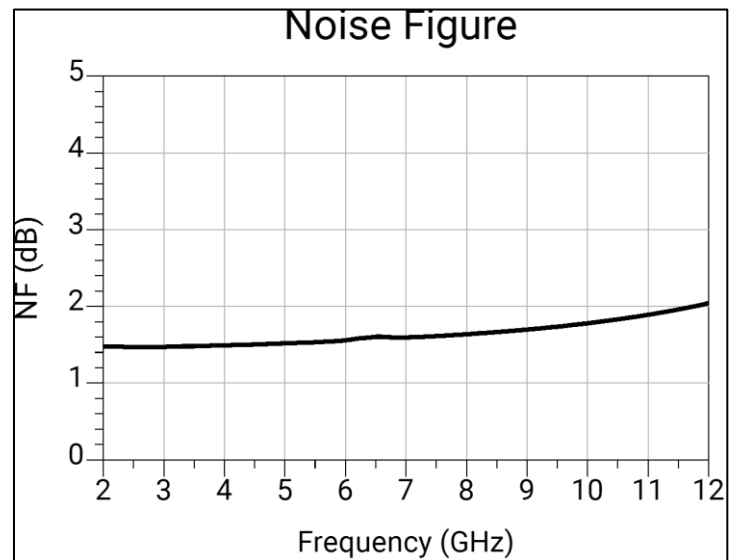
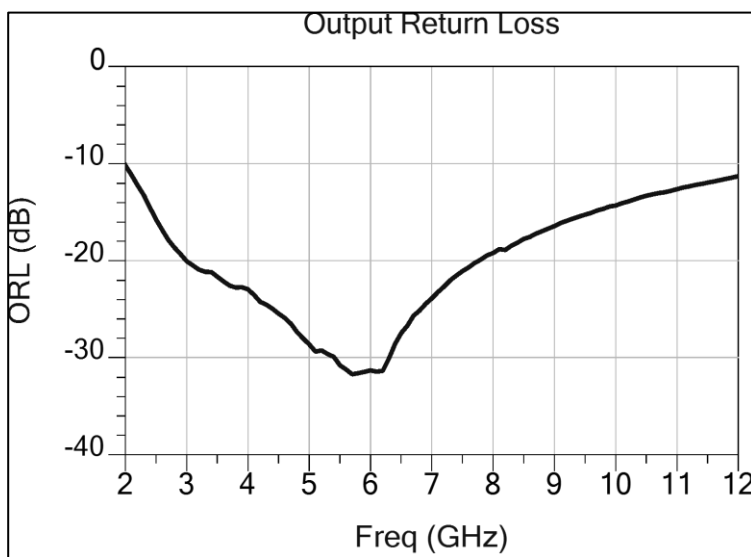
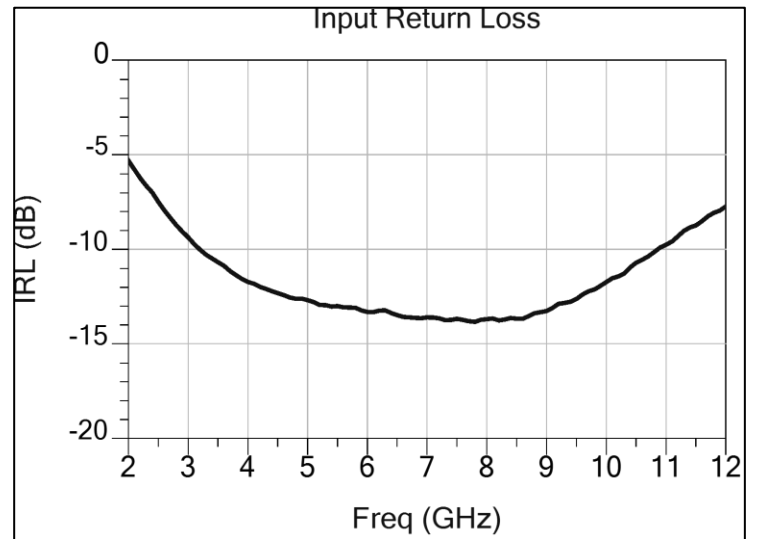
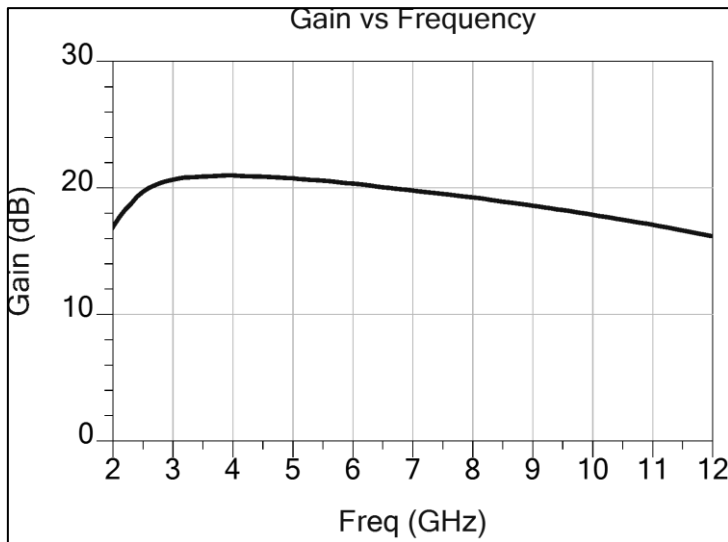

### EVB Measured Results:

#### Small Signal Analysis:

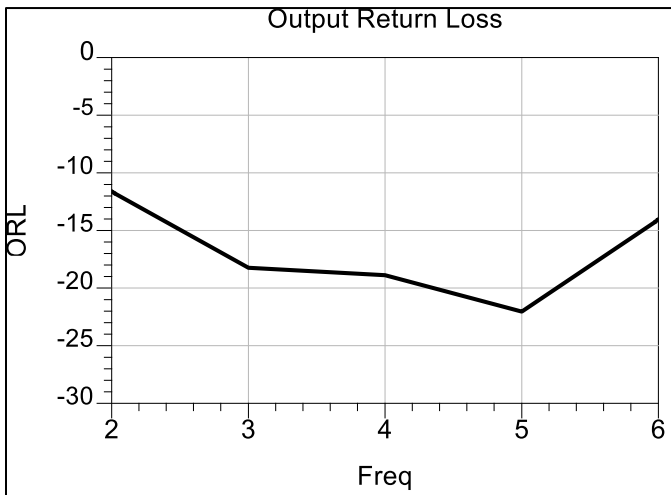
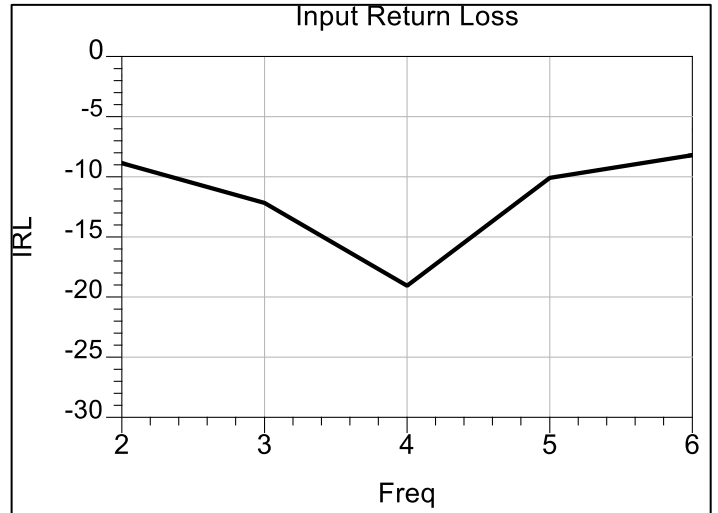
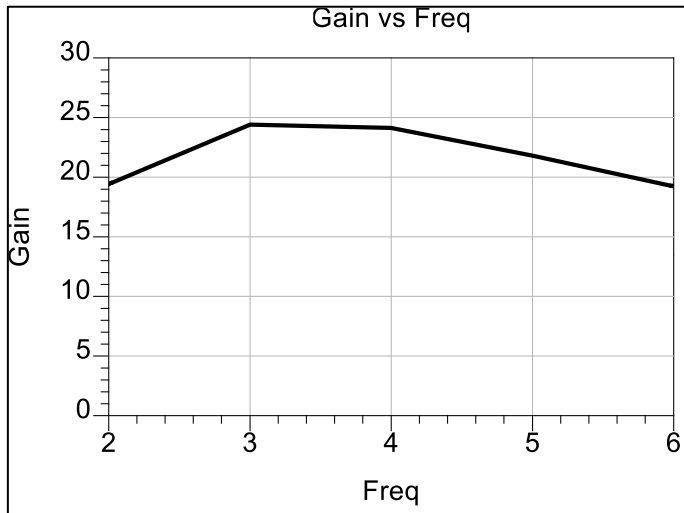

### Typical Performance Curves:

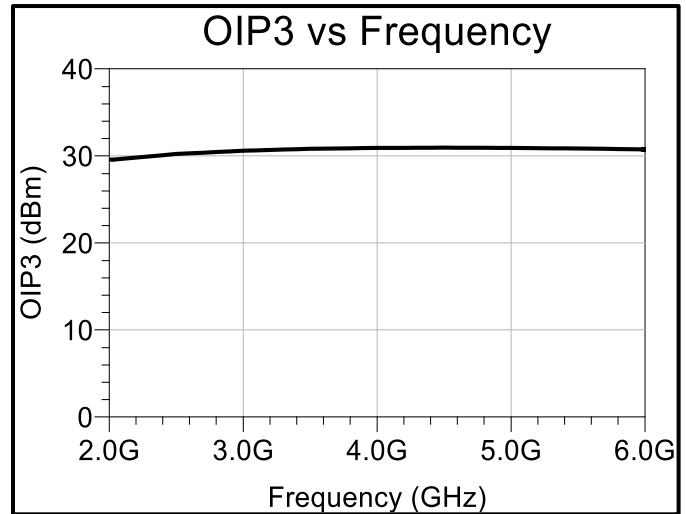
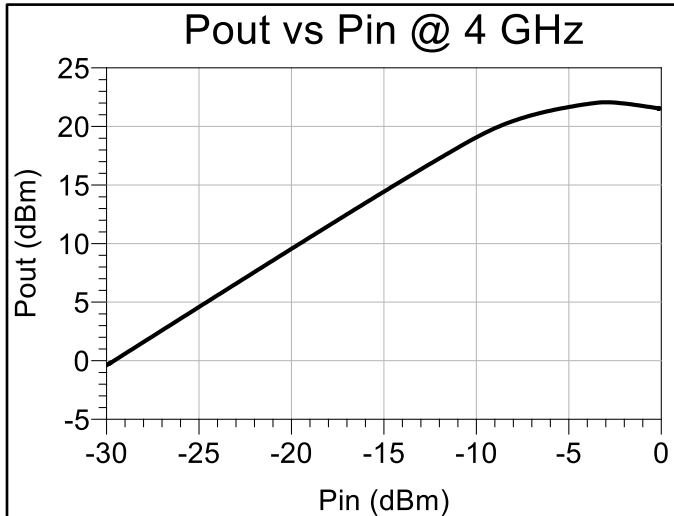

### Application Diagram:

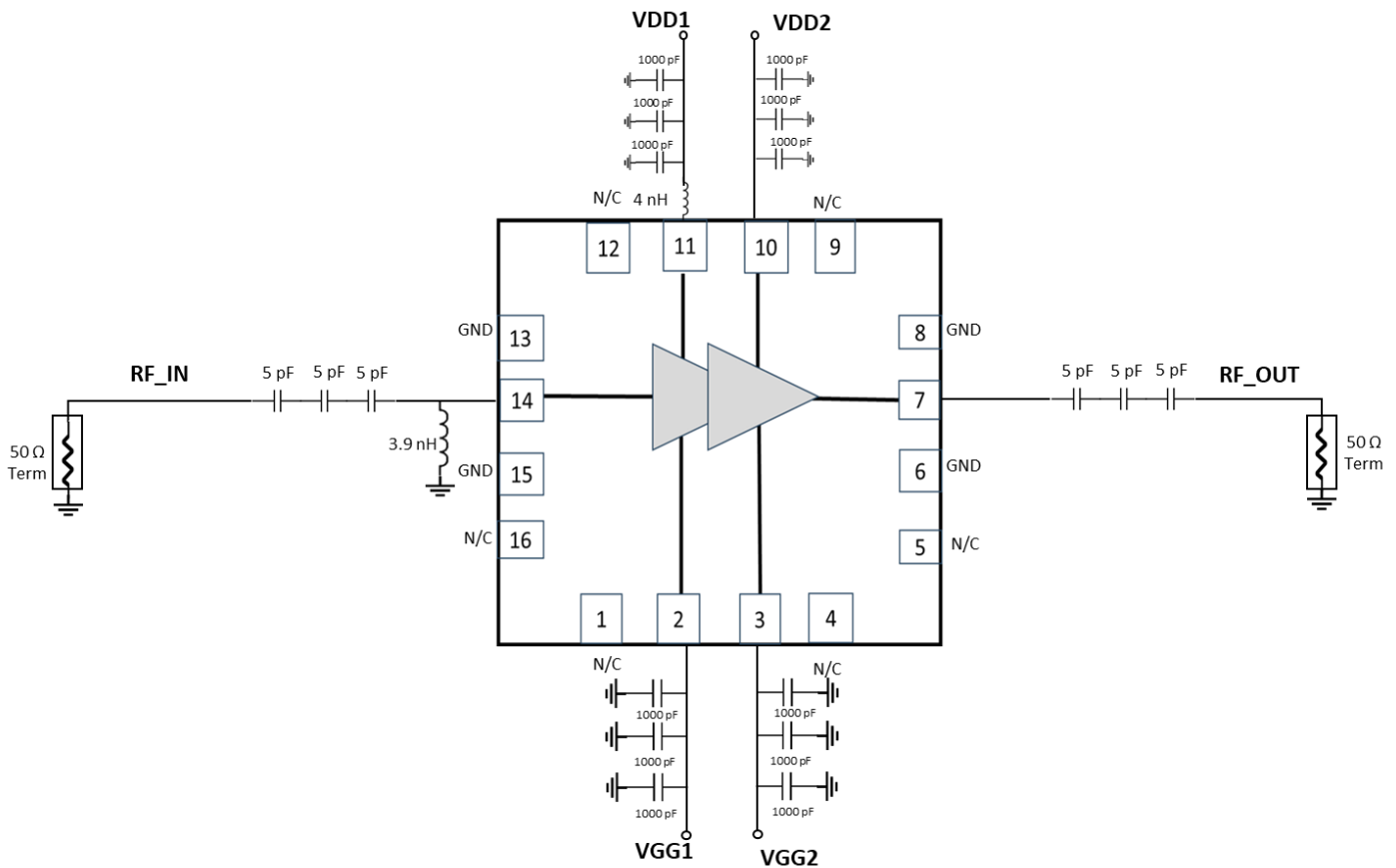

### Disclaimer:

Information in this document is provided in connection with Signify RF products. These materials are provided by Signify RF as a service to its customers and may be used for informational purposes only. Except as provided in Signify RF Terms and Conditions of Sale for such products or in any separate agreement related to this document, Signify RF assumes no liability whatsoever. Signify RF assumes no responsibility for errors or omissions in these materials. Signify RF may make changes to specifications and product descriptions at any time, without notice. Signify RF makes no commitment to update the information and shall have no responsibility whatsoever for conflicts or incompatibilities arising from future changes to its specifications and product descriptions. No license, express or implied, by estoppels or otherwise, to any intellectual property rights is granted by this document.

### Contact information:

For the latest specifications, additional product information:

Web: [www.signifyrf.com](http://www.signifyrf.com)

Email: [sales@signifyrf.com](mailto:sales@signifyrf.com)

Tel: (+1) 840 356 8957, (+91) 90220 78131, (+91) 84858 41789